

Hydramite



Powerful: 6.5 tonne, 10 tonne and 15 tonne capacity

Proven: thousands in use around the world

Well Engineered: servicing and repairs easily undertaken

Safe: relief valve prevents overloading

Compact and Lightweight: ideal portable tool

Versatile: operates in any orientation, totally enclosed and suitable for use in dusty conditions

Easy to Operate: lift/lowering controlled easily by operating lever

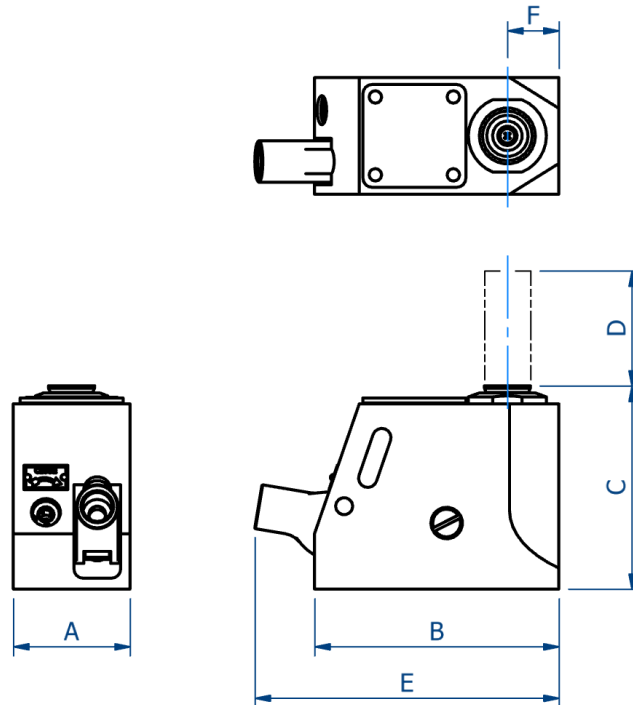

Product Code	8104H		1105002		1105003	
Capacity	6.5 tonne		10 tonne		15 tonne	
Lever Weight	1.7 kg	3.7 lbs	1.7kg	3.7lbs	1.7 kg	3.7 lbs
Jack Weight	3.6 kg	8 lbs	6.3kg	13.9 lbs	10.0 kg	22 lbs
Dimensions	mm	ins	mm	ins	mm	ins
A - Base Width	76	2.99	76	3	92	3.62
B - Base Depth	158	6.22	171	6.73	197	7.75
C - Closed Height	140	5.51	182	7.17	230	9.06
D - Stroke	75	2.95	115	4.5	152	5.98
E - Max Depth	190	7.48	207	8.15	236	9.29
F - Centre Ram to Face	33.3	1.31	40	1.57	48	1.89
Ram Diameter	30	1.18	38	1.5	47.5	1.87
Service Kit Number	995052		995053		995054	

