



DATASHEET

# HYDRACLAW JACK

5 Tonne



**Rugged and powerful. Ideal for mining & machine moving applications or where ground clearance is minimal.**

The Hydraclaw hydraulic jack offers a 5-tonne lifting capacity on both the head and toe and has the superior strength of steel whilst still remaining portable and easy to carry.

Its robust, ferrous construction can withstand rough treatment and is ideal for mining applications where aluminum components may spark and are not allowed.

#### Features and Benefits:

- **Powerful** - 5 tonne capacity on head or claw/toe.
- **Fast Operation** - 7/32" lift per stroke.
- **High Lift** - 7" stroke.
- **Low Clearance** - 1.6".
- **Versatile** - Can be used horizontally or vertically.
- **Stable** - Substantial base offers stability under load.
- **Safe** - Positive stop feature prevents over stroking and a pressure relief valve prevents overloading.

## Specifications & Dimensions:

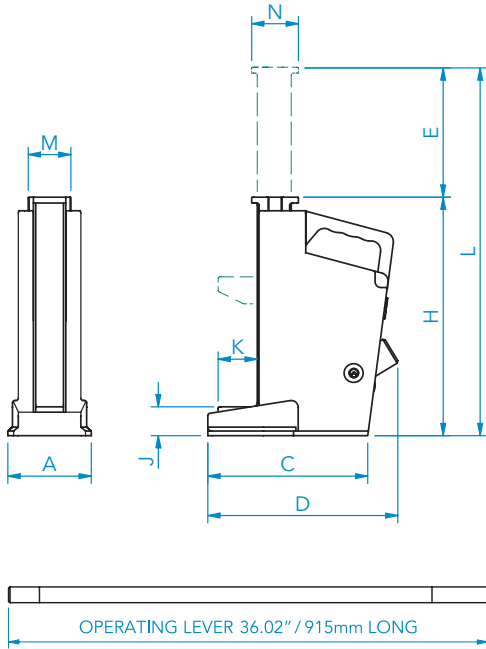

Model	9501W	
Capacity	5 Tonne	
Oil Capacity	1.19 Pints	0.68 Litres
Jack Weight	40 lbs	18 Kg
Lift per Stroke	0.21"	5.5mm
Max Handle Effort	99 Lbsf	45 Kgf
Operating Lever	7.72 Lbs	3.5 Kg
Dimensions	ins	mm
A - Width	4.49	114
C - Base Length	8.66	220
D - Overall Depth	10.24	260
E - Stroke	7.00	178
H - Closed Height	12.80	325
J - Claw Height Closed	1.61	41
K - Claw Depth	2.05	52
L - Extended Height	19.80	503
M - Ram Width	2.24	57
N - Ram Depth	2.52	64
Service Kit Number	995125	
Operating Lever	754030	