



## DATASHEET

# HYDRALITE JACK

6" CLAW/TOE MODEL  
20 / 30 / 60 Tonne



The aluminum Hydralite jack is one of the most popular out of the Tangye jack range.

This specific model has a 6" lifting range, extended base and removable claw/toe. It is available in capacities of 20, 30 and 60 tonnes.

### Features and Benefits:

- **Versatile** - The removable toe/claw allows lifting of structures and machinery with minimal ground clearance.
- **Portable** - Extensive use of high strength aluminum alloys minimizes jack weight for portability.
- **Minimum Operator Effort** - Full capacity is achievable with one operator. The short lever is lightweight and requires little space for operation.
- **Easy Operation** - The operating lever can be fitted in any one of the three positions in the quadrant to obtain the most suitable operating height.
- **Reliable** - All moving parts are totally enclosed and lubricated by the hydraulic oil. Seals are highly resistant to deterioration under widely varying climatic conditions.
- **Easy to Maintain** - The Hydralite jack's design makes inspection and component replacement uncomplicated. Refer to service instructions for guidance.
- **Safe** - Positive stop feature prevents over stroking and a pressure relief valve prevents overloading.

## Specifications & Dimensions:

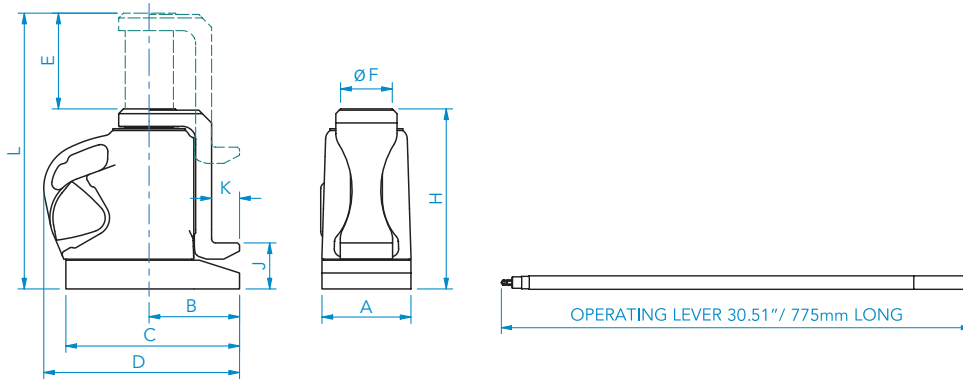

Model	PS620C		PS630C		PS660C	
Capacity	20 Tonne		30 Tonne		60 Tonne	
Claw / Toe Capacity	8 Tonne		12 Tonne		24 Tonne	
Oil Capacity	1.13 Pints	0.64 Litres	1.55 Pints	0.88 Litres	3 Pints	1.71 Litres
Jack Weight	24 lbs	10.90 kg	34 lbs	15.40 kg	61 lbs	27.4 kg
Claw Weight	8.8 lbs	4.0 kg	12.4 lbs	5.6 kg	34.2 lbs	15.5 kg
Lift per Stroke	0.042"	1.1mm	0.026"	0.70mm	0.013"	0.3mm
Working Pressure	9,900 PSI	682 Bar	9,350 PSI	644 Bar	9,350 PSI	644 Bar
Effort on Lever (max)	120 lbs	54 kg	115 lbs	52 kg	115 lbs	52 kg
Operating Lever	4.85 lbs / 2.2 kg					
Dimensions	ins	mm	ins	mm	ins	mm
A - Width	4.76	121	5.51	140	7.48	190
B - Centre Ram to Base	4.92	125	5.63	143	7.13	181
C - Base Length	9.69	246	10.75	273	13.35	339
D - Overall Depth	10.98	279	11.93	303	14.80	376
E - Stroke	6.00	152	6.00	152	6.00	152
F - Ram Diameter	2.36	60	2.99	76	4.25	108
H - Closed Height	10.91	277	11.10	282	12.91	328
J - Claw Height Closed	2.64	67	2.87	73	2.87	73
K - Claw Depth	1.61	41	1.77	45	1.89	48
L - Extended Height	16.91	429	17.10	434	18.91	480
<b>Service Kit Number</b>	<b>133506</b>		<b>133511</b>		<b>133518</b>	
<b>Operating Lever</b>	<b>993002</b>					